

# EVOLUTION JUNIOR

# Ex de FLOODLIGHT

The Evolution Junior is a lightweight high performance floodlight especially suited for temporary and portable lighting.

The design features a revolutionary concept where the essential flame-proof path needed for access to the lamp is inside the increased safety terminal chamber and is entered by a hinged cover with a single captive screw.

This feature is very useful in temporary and transportable applications where lamps may need to be replaced frequently.

Lamps up to 300W tungsten-halogen can be used.

The fixed floodlight version uses tubular HPS and metal halide lamps up to 70W. Explosion protection for gas group IIC (Hydrogen) is standard and a low temperature version for gas group IIB at -50°C is available.



## Standard Specification

## Features

Type of Protection	Ex de (Flameproof, Increased Safety)
ATEX Classification	Group II Category 2 G
Area Classification	Zone 1 and Zone 2 areas to EN 60079-10 with installation to EN 60079-14. Gas Groups IIA, IIB and IIC
Apparatus Standard Certificate	EN 50014 EN 50018 EN 50019 EC Type Examination Certificate BAS99ATEX2228
Coding	⊕ II 2 G EEx de IIC (refer to table for T rating and Ambient)
Enclosure	Aluminium alloy LM6 to BS 1490. All fastenings stainless steel. Toughened glass window
Reflector	Wide beam, high purity anodised aluminium
Entry	2 x M20 cable entries
Termination	3 core 6mm <sup>2</sup> max. conductor with looping
Installation	Stirrup mounting bracket
Lamp Type	HPS, Metal Halide or Double Ended Linear Tungsten-Halogen
Lampholder	R7s or E27
Control Gear	Internal copper/iron with PFC correction capacitor
Relamping	Access via hinged end cover on release of single screw
Burning Position	Universal for HID, +/-45° on horizontal axis for Tungsten-Halogen Lamps
Ingress Protection	IP66/67 to EN 60529
Electrical Supply	220, 230, 240, 254V 50Hz (HID) 24V(ac/dc)-250V (dependant on voltage)

Installation in gas groups IIA, IIB and IIC

Easy and quick access for maintenance

Simple, rapid lamp replacement and flamepath inspection

Exceptional photometric efficiency

GOST Approved

CEPEL Approved

### Applications

Zone 1 and 2 hazardous areas  
Temporary and transportable lighting  
Offshore oil and gas platforms  
Chemical industry  
Distilleries  
Aircraft hangers  
Tank farms  
Sewage treatment plants  
Security and perimeter lighting  
General area floodlighting  
Gas pumping stations  
Pharmaceutical industry  
Drum storage areas  
Gas line repairs

Chalmit Lighting, 388 Hillington Road, Glasgow G52 4BL

Tel: +44 (0) 141 882 5555 Fax: +44 (0) 141 883 3704

Email: [info@chalmit.com](mailto:info@chalmit.com)

[www.chalmit.com](http://www.chalmit.com)

Std. Cat No.	Wattage	Lamp	Lampholder	T Class	Ambient °C	Weight
EVJD/070/MS	70W	HPS and Metal Halide	E27	T4	40	12kg
EVJD/070/MS	70W	HPS and Metal Halide	E27	T3	55	12kg
EVJD/300/TL	150W	Tungsten-Halogen	R7s	T3	55	10kg
EVJD/300/TL	200W	Tungsten-Halogen	R7s	T3	40	10kg
EVJD/300/TL	250W	Tungsten-Halogen	R7s	T3	20	10kg
EVJD/300/TL	250W	Tungsten-Halogen	R7s	T2	50	10kg
EVJD/300/TL	300W	Tungsten-Halogen	R7s	T2	40	10kg
EVJD/150/TL/24	150W 24V	Tungsten-Halogen	R7s	T3	55	10kg

### Secondary Glass Shield Cat Nos.

EVJD/300/TL/GS	150W	Tungsten-Halogen	R7s	T3	55	10kg
EVJD/300/TL/GS	200W	Tungsten-Halogen	R7s	T3	25	10kg
EVJD/300/TL/GS	200W	Tungsten-Halogen	R7s	T2	50	10kg
EVJD/300/TL/GS	250W	Tungsten-Halogen	R7s	T2	40	10kg
EVJD/150/TL/24/GS	150W 24V	Tungsten-Halogen	R7s	T3	55	10kg

### Options - Suffix to Catalogue No.

/60	60Hz	/FS	Suitable for use with floor stand (floor stand should be ordered separately)
/M25	M25 Entries	/CGP	3 core 1.5mm cable c/w Ex gland, Industrial 110V plug
/P	PTFE coating		(only when luminaire is supplied with cable fitted - cable should be ordered separately)
/Y	Yellow painted version		
/LT	Low temperature version -50°C (IIA & IIB only)	/CG	Cable and Ex gland fitted (order cable separately)

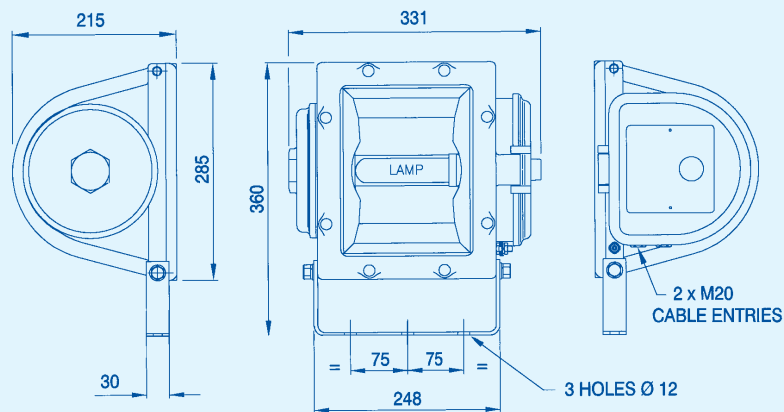

### Accessories (Should be ordered separately)

### Catalogue Order Code

Pole mounting brackets	SEVJ4-0003
Anti-glare shield	SEVJ4-0001
Wire guard	SEVJ4-0002
Floor stand assembly (to be ordered with floor stand version of floodlight)	SEVJR-0001
Tripod stand assembly	SEVJR-0002
Cable (ordered per metre)	E0414-0009
Ratchet handles (2 off) for adjustable aiming	SEVJR-0005
M20 brass, zinc plated Ex e gland	E0420-2020

Product design and specifications are subject to change without notice, please check the Chalmite website for latest specifications.