

The 216 well-glass luminaire is ideal for use where a compact, robust and efficient source of localised lighting is needed.

The range accommodates high pressure discharge lamps up to 80W Mercury Vapour and 70W HPS also incandescent up to 200W and compact fluorescent lamps up to 26W.

The 216 is made from corrosion resistant aluminium alloy and toughened boro-silicate glass using stainless steel fastenings and has an IP66/67 rating.

The luminaire features a large side mounted increased safety terminal chamber eliminating the need for flame-proof cable glands and allowing flush mounting.



Standard Specification

Features

Type of Protection	Ex de (Flameproof, Increased safety)	Highly resistant to mechanical damage and corrosion
ATEX Classification	Group II Category 2 G	Stainless steel fasteners
Area Classification	Zone 1 and Zone 2 areas to EN 60079-10 with installation to EN 60079-14 Gas Groups IIA and IIB	Compact and efficient
Apparatus Standard	EN 50014 EN 50018 EN 50019	Ex e terminal chamber
Certificate	EC Type Examination Certificate BAS01ATEX2307	Compact fluorescents have 6 times the life of tungsten lamps and consume 80% less power. They can be easily controlled by ac/dc supplies using high efficiency electronic control gear
Coding	⊕ II 2 G EEx de IIB (refer to table for T rating and ambient)	Anchor chain on glass cover assembly
Enclosure	Aluminium alloy LM6. All fastenings stainless steel. Toughened glass bowl	Suitable for use down to -50°C ambient
Reflector	High purity anodised aluminium	GOST Approved
Entry	2 x M20 cable entries	
Termination	3 core 6mm ² max. conductor with looping	
Installation	Flush mounting bracket	
Control Gear	Internal copper/iron with PFC correction capacitor	
Relamping	Access via front glass cover assembly	
Lampholder	E27 for GLS and HID lamps. G24q for compact fluorescent	
Lamp Type	High Pressure Sodium, Mercury Vapour, GLS and Compact Fluorescent	
Burning Position	Universal	
Ingress Protection	IP66/67 to EN 60529	
Electrical Supply	220,230,240,254V 50Hz (H.I.D) 250V max (GLS) 240V (CF)	

Std. Cat No.	Wattage	Lamp	Lampholder	T Class	Ambient°C	Weight
216D/050/HS	50W	HPS	E27	T4	50	9.5kg
216D/070/HS	70W	HPS	E27	T4	40*	10kg
216D/080/MV	80W	Mercury Vapour	E27	T4	40	10kg
216D/100/GL	100W	GLS	E27	T4	55	9.5kg
216D/200/GL	200W	GLS	E27	T3	55	9.5kg
216D/113/CF	1x10/13W	4-pin Compact Fluor	G24q	T6	55	9.5kg
216D/118/CF	1x18W	4-pin Compact Fluor	G24q	T5	55	9.5kg
216D/126/CF	1x26W	4-pin Compact Fluor	G24q	T5	55	9.5kg
216D/213/CF	2x10/13W	4-pin Compact Fluor	G24q	T5	40	10kg
216D/218/CF	2x18W	4-pin Compact Fluor	G24q	T5	40	10kg

* 45°C ambient version available as option

Options - Suffix to Catalogue No.

/___	Specific voltage (12,24,50,110,120, 130 compact fluorescent)
/60	60Hz
/M25	M25 Entries
/P	PTFE coating
/2P	2 Pin compact fluorescent version c/w switch start control gear (single lamp version only)
/S	Stirrup mounting bracket
/BC	BC lampholder for GLS versions
/45	+45 °C Ambient for 70W HPS version only

Applications

Zone 1 and 2 hazardous areas
 Offshore oil and gas platforms
 Harsh and low temperature environments
 Low bay lighting
 Gantry and walkway lighting
 Stairwells • Process skid manufacturing
 Sewage treatment plants
 Road tanker loading facilities
 Oil jetties

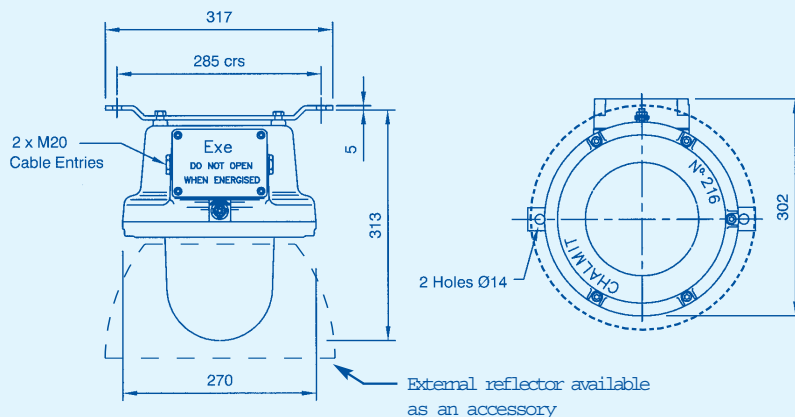

Accessories (Should be ordered separately)

Catalogue Order Code

Pole mounting bracket (stirrup mounting version only)	S2160-0002
Pole mounting bracket c/w stirrup (retro fit for flush mounting bracket)	S2160-0004
Wire guard	S2160-0007
External reflector	S2160-0010

Product design and specifications are subject to change without notice, please check the Chalmitt website for latest specifications.

