

The Sterling stainless is a robust quality luminaire designed to provide instant glare free white light at low mounting heights.

The stainless steel body and polycarbonate diffuser secured with multiple stainless steel clips ensure excellent corrosion resistance and rapid access for installation and maintenance. The stainless steel body is designed to provide high impact strength and resistance to those chemicals which might damage GRP. The protection is Ex n for ignitable gas applications and dust excluding, IP6X, for use in ignitable dust applications.

The Sterling is certified under the ATEX 94-9-EC directive for Categories 3 G and 3 D. The range is suitable for T8 tubular fluorescent lamps in 18/38/58W sizes. Electronic high frequency control gear is fitted as standard, conventional low loss control gear with electronic start is also available as an option.

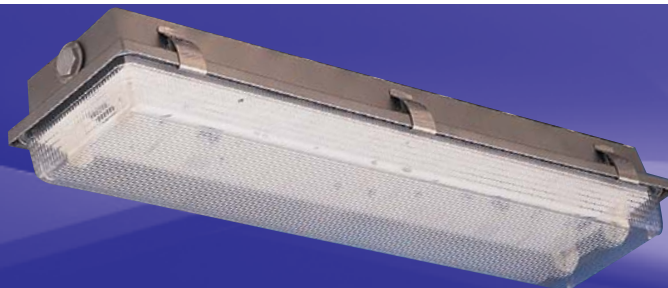

Standard Specification

Features

Type of Protection	Ex nA (Non-sparking) Dust protected enclosure	Marine grade stainless steel body and polycarbonate diffuser
ATEX Classification	Group II Category 3 G D	
Area Classification	Zone 2 and Zone 22 areas to EN 60079-10 and EN 50281-3 with installation to EN 60079-14 and EN 50281-1-2	3 clips per side on 18W, 4 on 36W and 5 on 58W
Apparatus Standard Certificate	EN 50021 EN 50281-1-1 EC Type Examination Certificate BAS01ATEX3052X	Mains connection terminals fixed to body
Coding	⊕ II 3 G D EEx nA II (refer to table for T rating and Ambient)	Gear tray suspended and fitted with control gear for ease of maintenance
Enclosure	Marine grade stainless steel body with polycarbonate diffuser and stainless steel retaining clips	High frequency control gear gives 50/60Hz operation, high power factor correction and regulation of lamp output.
Reflector Entry	White polyester painted zinc coated steel 3 x 20mm diameter holes, 2 at one end and 1 at the other end	
Termination	3 core 4mm ² max. conductor with looping and through wiring 16A rating	
Installation	Two clearance holes for M8 fasteners located on rear of body, sealing washers provided	
Lampholder Lamp Type	G13 (Bi-pin) T8 tubular fluorescent	
Control Gear	High Frequency ballast housed within sealed enclosure	
Relamping	Access via front diffuser secured by quick release stainless steel clips	
Burning Position	Universal	
Ingress Protection	IP65 to EN 60529	
Electrical Supply	220-240V 50/60Hz, 254V 50Hz (Other voltage and frequencies available)	

ATEX CATEGORY 3 ZONE 2 & 21 APPLICATIONS

Std. Cat No.	Wattage	T Class (Gas)	T°C (Dust)	Ambient °C	Weight
STSN/118/BI*	1x18W	T4	95	45	4.2kg
STSN/218/BI	2x18W	T4	95	45	3.6kg
STSN/136/BI*	1x36W	T4	95	50	4.2kg
STSN/236/BI	2x36W	T4	95	50	4.8kg
STSN/158/BI*	1x58W	T4	95	40	6.1kg
STSN/258/BI	2x58W	T4	95	35	6.5kg

* Single lamp versions are in twin bodies.

Dust only version (STSU/___) available. Contact sales for information.

Options - Suffix to Catalogue No.

- /___ Specific voltage (120, 220 or 254 copper & iron versions only)
- /ES Copper and iron control gear
- /60 60Hz (copper and iron versions only)
- /MF Mains fuse
- /25 3 x 25mm cable entries attached
- /CM c/w offset ceiling mounting brackets
- /TE Threaded entry pads
- /EB End mounting brackets attached
- /EL Extra live termination (compatible with 4-core switched emergency circuits)

Applications

- Zone 2 hazardous areas
- Harsh and corrosive environments
- Petrochemical process areas
- Pharmaceutical industry
- Tunnel lighting
- Sewage treatment plants
- Distilleries
- Walkways

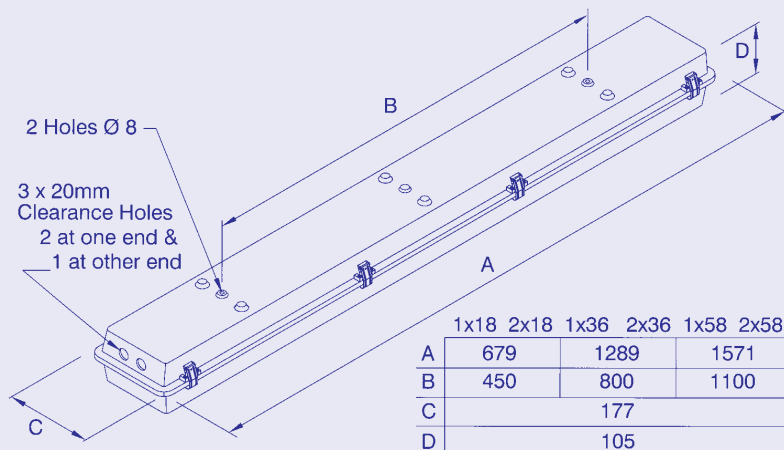

Accessories (Should be ordered separately)

Catalogue Order Code

Pole mounting bracket assembly (38/50 diameter poles)	SSTGN-1008
C' form hook type ceiling bracket assembly	SSTGN-0007
Flush mounted wall bracket assembly	SSTGN-0006
18W wall mounting outreach bracket (use with SSTGN-1008)	NPRO4-0008
36W wall mounting outreach bracket (use with SSTGN-1008)	NPRO4-0012
58W wall mounting outreach bracket (use with SSTGN-1008)	NPRO4-0022

Product design and specifications are subject to change without notice, please check the Chalmit website for latest specifications.



Electrical Products