 GENERI, s.r.o. Uničovská 50 787 01 ŠUMPERK Czech Republic tel.: +420583221500 fax: +420583214183	OPERATING INSTRUCTIONS	Page: 1 of 3
	EXPLOSION-PROOF STEEL LV SWITCHGEAR UP TO 10kA WITH THE DIRECT ENTRY INTO A FLAMEPROOF ENCLOSURE	N740017/2- 3 th issue
TYPE: X40..DA2/d	I M2 Ex d I Mb II 2G Ex d IIC T6, T5 Gb II 2D Ex tb IIIC T85°C, T100°C Db	Valid from: 20.4.2016

GENERAL

These operating instructions conform to:

- Technical requirements for equipment and protective systems intended for use in potentially explosive atmospheres (2014/34/EU).
- Technical requirements for products from the point of their electromagnetic compatibility (2014/30/ EU).

These operating instructions are not valid for switchgear of type X40..DA2/d (with the indirect entry into a flameproof enclosure)!



SAFETY INSTRUCTIONS AND UNSUITABLE USE
 Do not leave these operating instructions inside the box during operation!

- Do not operate switchgears X40..DA2/d in hazardous areas **ZONE 0** (EN 60 079-10-1), **ZONE 20** (EN 60 079-10-2) and in **explosive atmospheres** (EN 1127-2)!
- Used **cable glands** must be constructed according to the **Ex "d"** method of protection, meet the requirements of EN 60079-1 standard, must be **certified as Ex equipment** and properly marked!
- For **cable entries via cable glands with a compressed ring** use only **circular and compact cables** sheathed with thermoplastic, thermosetting or elastomeric material. **Filler**, if any, shall be **extruded** and non-hygroscopic. **Cable length must be at least 3 m!**
- Some types of **mine cables** (e.g. CBEH) contain a **strippable semiconducting core screen**. This screen **must be always removed** before wires connection!
- The components with **hot surfaces** can be inside the switchgear, thus with a danger temperature! Open the switchgear without presence of explosive atmosphere or while is NOT energized after enough long time after switch off so that the hot parts become cold!
- Switchgears X40..DA2/d are not intended for untrained personnel**. Installation, commissioning and any service must be performed by skilled electricians and in accordance with safety rules.
- Operate** switchgears X40..DA2/d in accordance with below mentioned operating conditions, technical and name plate data.
- Do not replace interior content** of switchgear with equipment that is **in contradict with supplied documentation** (e.g. replacement of circuit breaker 6A by circuit breaker 10A).
- When a residual current devices (RCD) are assembled, then min. 1 x per 6 months, check their function by test button (with keeping of appropriate safety rules).**
- Switching and protective devices inside the box can produce **short-term electromagnetic interference**, so they must be operated in areas where no negative influence to other equipment is.
- Storage, transport, mounting, installation, revision and preventive service, repairs and service to be executed according to following instructions.

1. USING

Switchgears X40..DA2/d are determined for installation in hazardous areas with a danger of explosion of inflammable gases and vapours, combustible dust and explosives, or in underground mines with occurrence of methane.

2. OPERATING CONDITIONS

2.1 External influences acc.to IEC60 364-5-51 - cat. A: ENVIRONMENT

Code	Description of external influence	Specification
AA	Ambient temperature (max. range) *	-60°C to +60°C
AB	Atmospheric humidity	to +30°C ... 100% to +40°C ... 70%
AD5	Presence of water	Jets
AE6	Presence of foreign solid bodies or dust	Heavy dust
AF4	Presence of corrosive or polluting substances	Continuous
AG3	Mechanical shock	High severity (7J resp. 20J)
AH	Vibrations	See art. 6. – rev.

* Concrete temperature range depends on used components and it is always mentioned on name plate, if the equipment is produced for ambient temperature range different than standard range -20°C to +40°C.

2.2 External influences acc.to IEC 60 364-5-51- cat. B: USE

Code	Description of external influence	Specification
BE3N1	Danger of explosion of inflammable dusts	see point 2.4
BE3N2	Danger of explosion of inflammable gases and vapours	see point 2.4
BE3N3	Danger of fire or explosion of explosives	see point 2.4
BA5	Capability of persons	skilled
BC3	Contact of persons with earth potential	frequent

2.3 Not mentioned external influences are in accordance with IEC 60 364-5-51 normal.

2.4 Use in areas and environments according to regulations

Areas	Name of standard	Standard
Potentially explosive atmospheres (I M2 version)	Explosive atmospheres - Explosion prevention and protection - Part 2: Basic concepts and methodology for mining	EN 1127-2
ZONE 1 ZONE 2	Explosive atmospheres - Part 10-1: Classification of areas - Explosive gas atmospheres	EN 60 079-10-1
ZONE 21 ZONE 22	Explosive atmospheres - Part 10-2: Classification of areas - Combustible dust atmospheres	EN 60 079-10-2

2.5 Operating position: vertical

3. TECHNICAL DATA

Name	Data	Standard, note
Type of protection ¹⁾	Ex d I Mb Ex d IIC T6,T5 Gb Ex tb IIIC T85°,T100°C Db	EN 60 079-0 EN 60 079-1 EN 60 079-31
Ingress protection	IP 66	EN 60 529
Group and category ¹⁾	I M2, II 2G, II 2D	2014/34/EU
Certification	FTZÚ 02 ATEX 0354X	FTZÚ NB 1026, CZ
Version of switchgear	LV switchgear Power switchgear	EN 61 439-1 EN 61 439-2
Rated voltage and current	See name plate	
Rated short-time current	Max. 10 kA	EN 61 439-1
Protect. class	I	EN 61 140
External PE	16 mm ²	2x screw M5 + shim
EMC	Switchboard without in-built electronic parts resistant to elm. interference radiating short-term elm. interference	Acc. to EN 61 439-1 no other verification is required
	Switchboard with in-built electronic parts resistant to elm. interference Not radiating short-term elm. interference	acc. to harmonized IEC standards for EMC
Material	steel 11 373	weldment
Surface finish	Powder baking coating	Grey, RAL7040

¹⁾ Concrete data are mentioned on name plate

**GENERI, s.r.o.**
 Uničovská 50
 787 01 ŠUMPERK
 Czech Republic

tel.: +420583221500 fax: +420583214183

OPERATING INSTRUCTIONS

Page: 2 of 3

**EXPLOSION-PROOF STEEL LV SWITCHGEAR UP TO 10kA
 WITH THE DIRECT ENTRY INTO A FLAMEPROOF ENCLOSURE**
N740017/2- 3th issue
 TYPE:
X40..DA2/d

 I M2 Ex d I Mb
 II 2G Ex d IIC T6, T5 Gb
 II 2D Ex tb IIC T85°C, T100°C Db

Valid from: 20.4.2016

4. INSTALLATION INSTRUCTIONS**4.1 Mounting dimensions**

Switchgears are standardly supplied with mounting U-profiles. For smaller types there can be welded feet instead of U-profiles provided. Alternatively it is possible to mount switchgear directly by 4 screws "M" from the back of switchgear (dimension "b").

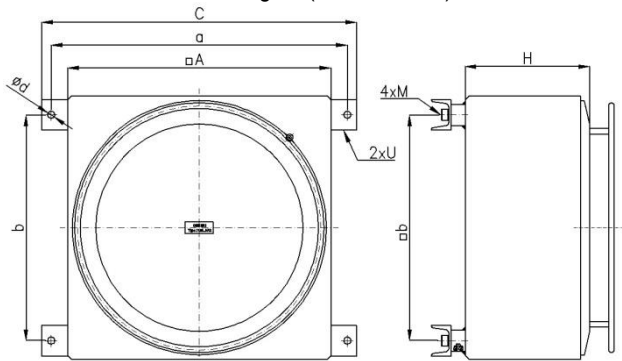

Type	A	H	C	a	b	d	M	U
X4011DA2/d	160	125	240	210	100	11	M10	U50
X4012DA2/d	160	165	240	210	100	11	M10	U50
X4031DA2/d	260	125	340	310	200	11	M10	U50
X4032DA2/d	260	165	340	310	200	11	M10	U50
X4033DA2/d	260	225	340	310	200	11	M10	U50
X4034DA2/d	260	265	340	310	200	11	M10	U50
X4052DA2/d	330	165	420	390	270	13	M12	U50
X4053DA2/d	330	225	420	390	270	13	M12	U50
X4054DA2/d	330	265	420	390	270	13	M12	U50
X4055DA2/d	330	325	420	390	270	13	M12	U50
X4062DA2/d	360	165	450	420	300	13	M12	U50
X4063DA2/d	360	225	450	420	300	13	M12	U50
X4064DA2/d	360	265	450	420	300	13	M12	U50
X4065DA2/d	360	325	450	420	300	13	M12	U50
X4072DA2/d	400	165	490	460	340	13	M12	U50
X4073DA2/d	400	225	490	460	340	13	M12	U50
X4074DA2/d	400	265	490	460	340	13	M12	U50
X4075DA2/d	400	325	490	460	340	13	M12	U50
X4076DA2/d	400	365	490	460	340	13	M12	U50
X4082DA2/d	500	165	610	570	420	15	M14	U65
X4083DA2/d	500	225	610	570	420	15	M14	U65
X4084DA2/d	500	265	610	570	420	15	M14	U65
X4085DA2/d	500	325	610	570	420	15	M14	U65
X4086DA2/d	500	365	610	570	420	15	M14	U65
X4092DA2/d	560	165	670	630	480	15	M14	U65
X4093DA2/d	560	225	670	630	480	15	M14	U65
X4094DA2/d	560	265	670	630	480	15	M14	U65
X4095DA2/d	560	325	670	630	480	15	M14	U65
X4096DA2/d	560	365	670	630	480	15	M14	U65
X4097DA2/d	560	425	670	630	480	15	M14	U65

All dimensions in "mm"

4.2 Cable entries

Use only cable glands constructed according to Ex "d" method of protection (EN 60079-1) **certified as Ex equipment**. There can be used either **barrier cable glands** or **cable glands with compressed ring**. When use cable glands with compressed ring, pay attention to **choice of suitable cable type** – see "Safety instruction and unsuitable use".

Each cable gland is able to seal only a defined range of cable diameter. In case of higher number of cable glands it is necessary to insert and tighten the cable into the cable gland subsequently from one side to the other side (for instance from the left to the right) and also to start with cable gland on the lower row and continue with the cable glands above them.

To achieve a reliable degree of protection, tighten properly cable glands by specified tightening torque. Unused holes and openings for cable entries must be closed by certified plugs that comply with required degree and type of protection - see art.6.

4.3 Connection of wires to terminals

There are used either the cage clamp terminals or screw terminals. Their function is clear from the following pictures.

4.3.1 Cage spring terminals

By pressing a cage clamp of the terminal block (1) e.g. with a suitable screwdriver (or a special WAGO screwdriver supplied by customer's request) you unfasten space for the connection of a wire. By pushing of the wire (2) and releasing the cage clamp (3) a perfect current-carrying connection is created.

At connection of two adjacent terminal block with cage clamp by means of special blade jumper, press this jumper with power into both terminal blocks so that it does not overreach the terminal block (see following picture)

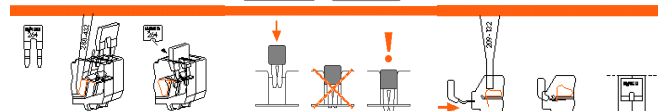
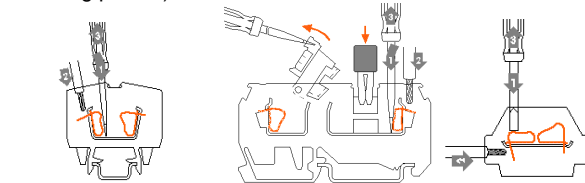

At some types of terminals with cage clamp it is necessary to use a greater one terminal when connecting a wire with a ferrule. E.g. for connection of a 2,5 mm² wire with the ferrule, it is necessary to use a terminal block 4,0 mm².

4.3.2 Screw terminals

Connect wires from the side of the terminal and properly tight the connection. If you **interconnect screw terminals** (see previous picture), properly tight screw jumpers.

If the PE or FE rail is installed and only one wire is to be connected to a terminal, it is necessary to bend the end of wire into a "U" shape so that the clamping plate compressing the wire is in-plane and the function of the flexible washer between the clamping plate and the screw head is not reduced.

4.3.3 General requirements

Stranded wires must be provided with ferrules. We recommend use **ferrules** also for full copper wires without surface protection and in **aggressive atmosphere**. Termination of stranded wires only by soft solder is not permitted!!!

You can **insert only one wire** in to the connection hole of terminal and **its maximum cross section must not be bigger than it is mentioned on the terminal block resp. on the nameplate.**

The wire insulation must reach as close the current-carrying connection as possible. The wire must not be damaged.

We recommend **regularly**, at least 1 a year (depending on the environment), **treat connection points of protection wires** (or other corrosive metal surfaces) with **grease**. It does not relate to stainless steel boxes.

Unused dead wires should be connected to unoccupied terminal (including of protective wires) or terminated in a way complying with valid regulations.

5. INSTALLATION ACC. TO VALID REGULATIONS

A decision to use the given type of equipment in a specific areas must comply with above mentioned operating conditions (see point 2), local operating regulations, **EN 60 079-14** and other valid regulations.

Electrical accident protection, in addition to said regulations, is stipulated by **IEC 60 364-4-41**, **EN 61 140** and other related regulations.

Safety regulations for operating personnel and work on electrical equipment are identified by **EN 50 110-1**.

 GENERI, s.r.o. Uničovská 50 787 01 ŠUMPERK Czech Republic tel.: +420583221500fax: +420583214183	OPERATING INSTRUCTIONS	Page: 3 of 3
	EXPLOSION-PROOF STEEL LV SWITCHGEAR UP TO 10kA WITH THE DIRECT ENTRY INTO A FLAMEPROOF ENCLOSURE	N740017/2- 3 th issue Valid from: 20.4.2016
TYPE: X40..DA2/d	I M2 Ex d I Mb II 2G Ex d IIC T6, T5 Gb II 2D Ex tb IIIC T85°C, T100°C Db	

6. INSPECTION AND PREVENTIVE MAINTENANCE

Inspection and preventive maintenance of electrical device is defined in **EN 60 079-17**, unless it is defined otherwise by a notice, local regulations etc.

The lid of enclosure is being opened by anticlockwise movement. Beforehand it is necessary to unscrew screw M8 with internal hexagon. Follow instructions in part **SAFETY INSTRUCTIONS AND UNSUITABLE USE**.

Before every screwing of lid it is necessary to clean and paint enclosure screw surface by thick layer of no solidifying grease without content of solvents against corrosion. Cleaning of the lid can be performed only by non-metal scraper and liquid which does not cause corrosion. **Renovation of grease on both of threads must be performed min. once a year.**

All mechanical and electrical connections are protected from self-loosening. Tests of devices on vibrations (external influence AH1, 2, 3 acc. to IEC 60 364-5-51) in relation to classes of climatic conditions acc. to EN 60 721-3-3 and EN 60 721-3-4 are not however performed. That is why, in case of **mobile equipment**, we recommend **carry out inspections at least 2-times a year as a detailed inspection acc. to EN 60 079-17.**

Cable glands and plugs can be replaced only by types with appropriate type of Ex and ingress protection and certified by the notified body. Where it is not possible to provide fixed installation of cables, it is necessary to use cable glands with a protection against pulling out (usually with clamping module) - it relates mostly to **mobile equipment**.

Other spare parts - see article 10.

7. REPAIRS AND MAJOR INSPECTIONS, SERVICE

Repairs and major inspections of explosion-proof electrical devices are defined in **EN 60 079-19**.

Repairs should be carried out only by the manufacturer or an organization authorized by the manufacturer.

Following parts **cannot be repaired**:

- glass window in steel lid
- thread joint in steel enclosure (box-lid)
- cable glands and plugs, bushings
- stainless steel screws in the lid of connecting box
- terminals, circuit breakers, contactors and other el. components

These parts must be replaced if damaged.

In case of any **repairs and renovations**, Ex type of protection and original degree of protection must be preserved.

Service is performed right in the manufacturing plant in Šumperk.

In case of any problems regarding the GENERI products (such as loss of accompanying documents, technical defects etc.), just read the two data on the rating plate:

- 1) TYPE OF EQUIPMENT
- 2) SERIAL NUMBER

On the basis of these data it is possible to find any accompanying and technical documents of concrete product at manufacturer.

8. STORAGE, PACKING AND TRANSPORT

Switchgears are **stored** at ambient temperature from +5°C to +40°C, in non-aggressive interior rooms without UV radiation and weather conditions, where the quality does not deteriorate (climatic conditions 1K2, biological conditions 1B1, chemical active compounds 1C2, mechanically active compounds 1S1 and mechanical conditions 1M2 according to EN 60 721-3-1).

Switchgears are **packed** in protective foils and supplied in carton boxes (bigger boxes can be attached to pallets).

Transport is ensured by express transport company within 24 hours, or according customer's wish. It is also possible to cash on delivery.

Transport conditions according to EN 60 721-3-2 are 2K2, 2B1, 2C2, 2S1, 2M2.

9. DELIVERY TERMS

Price of goods, delivery terms, methods of payment and transport are mentioned in a purchase contract which is sent by the business department after receiving your order. If it is not specified otherwise in the contract, a standard warranty 12 months for goods is provided.

10. SPARE PARTS

There is inserted a wiring diagram inside of switchgear, where used electrical components are specified.

11. DISPOSAL OF THE PRODUCT



Useless products should be disposed in accordance with valid regulations. !!! All components may produce harmful exhalations during combustion!!!

12. SUPPLIED DOCUMENTS

- EU declaration of conformity
- These Operation instructions including of warranty
- Wiring diagram inserted inside the switchgear
- Delivery note

Certificates according to point 3 are available on www.generi.cz or upon request.

WARRANTY

Product type:	X40 . . DA2/d	
Serial number	from:	to:
No.:		

You are provided with a warranty for a period of 12 months (if it is not specified otherwise in the purchase contract) valid from the day the product was handed over. We guarantee quality of work and material. Despite this, faults unidentifiable in the manufacturing plant may occur due to storage, during transport or use. If they were caused by faulty material or production, we shall restore the product to a trouble-free state at our own costs. The warranty does not apply to defects resulting from mishandling or mechanical damage and not following instructions for assembly and maintenance.

FINAL INSPECTION

Authorized person:	Result:	Stamp and signature:
	OK	
In Šumperk on:		



ISO 9001



WE WISH YOU MAXIMUM SATISFACTION WITH OUR PRODUCTS AND SERVICES

